

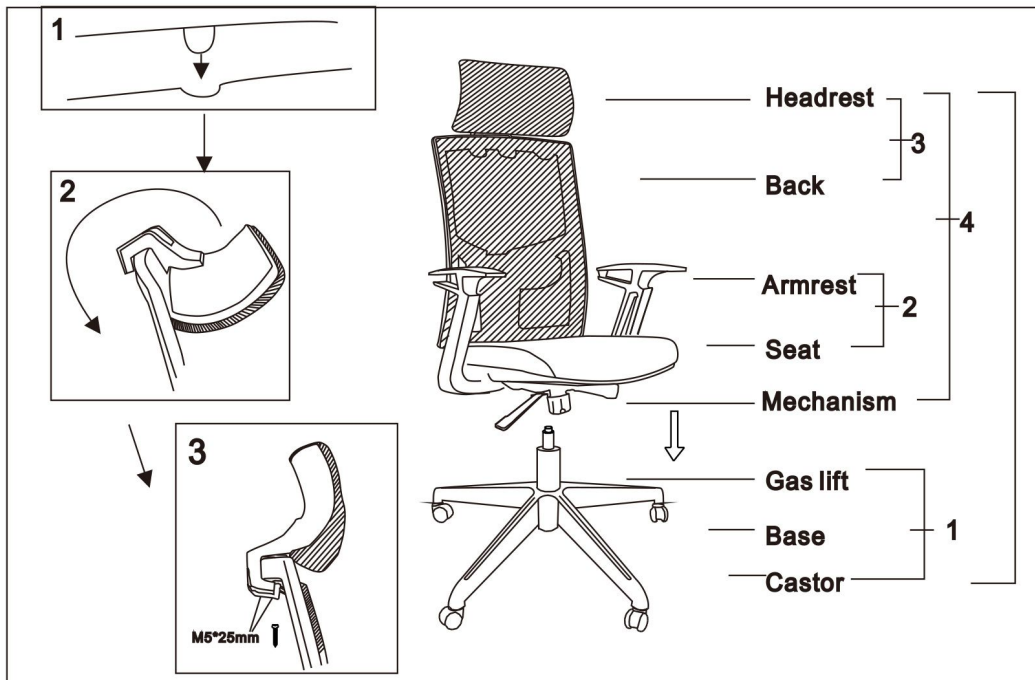

ASSEMBLY INSTRUCTIONS

" functional seating for today's workplace "

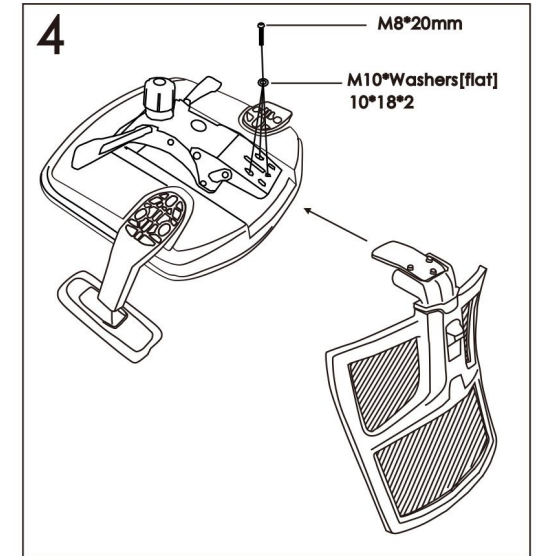
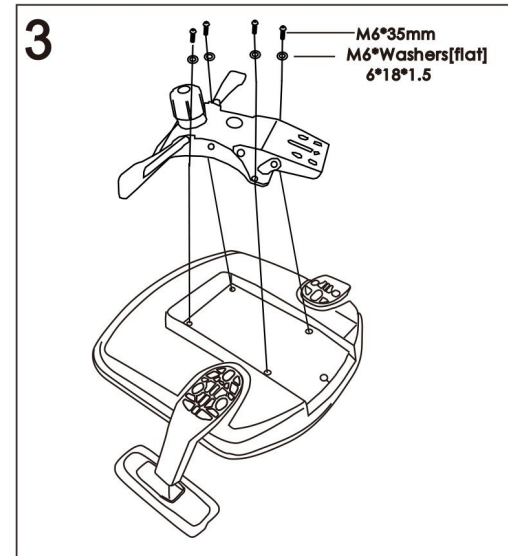
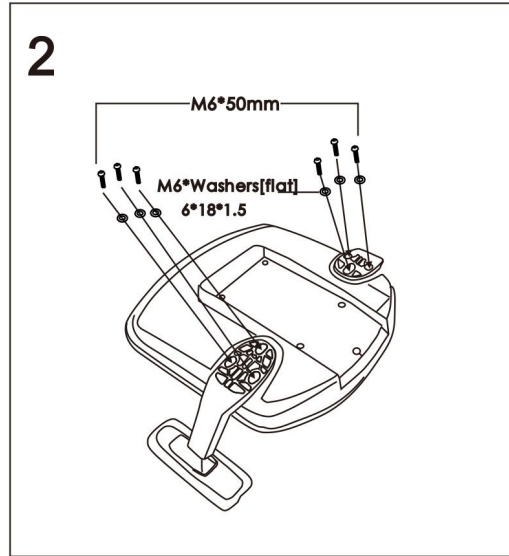
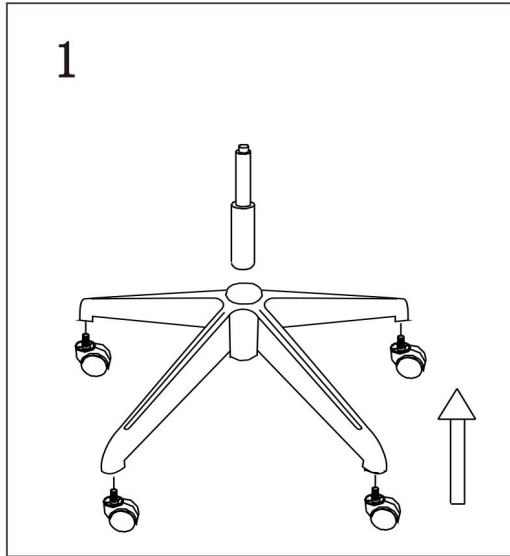

M6*50mm	6	M10	3
M6*35mm	4	M6	10
M8*20mm	3		
M5*25mm	2		

Use the ruler to help identify parts

Parts Checklist

PREVENTIVE MAINTENANCE AND WARNING

- ONLY FOR SEATING ONE PERSON AT A TIME.
- DO NOT USE CHAIR AS STEP STOOL OR LADDER.
- DO NOT USE CHAIR UNLESS ALL BOLTS, SCREWS ARE TIGHT.
- AT LEAST EVERY SIX MONTHS CHECK ALL BOLTS AND SCREWS TO BE SURE THEY ARE TIGHT.
- IF ANY PARTS ARE MISSING, BROKEN, DAMAGED OR WORN, STOP USING THE PRODUCT UNTIL REPAIRS ARE MADE WITH FACTORY AUTHORIZED PARTS.
- FAILURE TO FOLLOW THESE WARNINGS CAN RESULT IN SERIOUS INJURY.